

THE NAVAJO NATION

JONATHAN NEZ | PRESIDENT MYRON LIZER | VICE PRESIDENT



January 6, 2023

Hon. Otto Tso
Office of the Speaker
Post Office Box 3390
Window Rock, AZ 86515

RE: CD-70-22, *An Action Relating to the Naabik'iyáti' Committee, and the Navajo Nation Council; Approving the Navajo Nation Fiscal Recovery Fund Delegate Region Project Plan for Honorable Eugene Tso's Delegate Region (Chapter: Chinle)*

Dear Speaker Tso,

The Nez/Lizer Administration supports the Chapters' endeavors to work collaboratively with their respective Council Delegate in completing the process to access funding made available with the \$211,256,148 allocated for regional expenditure plans under CJN-29-22.

The process to secure funding also involves collaborative efforts between the Chapters, the Division of Community Development, Navajo Nation Fiscal Recovery Fund (NNFRF) Office and the Navajo Nation Department of Justice (NNDJ). Per BFS-31-21, each proposed expenditure must obtain NNDJ verification that each proposed project is an eligible expense within ARPA/NNFRF regulations. Each of the projects within CD-70-22 has met all the requirements.

The ARPA/NNFRF process is still evolving since the inception of this funding. Within the United States Treasury and the Navajo Nation, processes have been updated at various times. An example is the Treasury guidelines referenced within Navajo Nation Council resolutions CJY-41-21 and CJN-29-22; the Treasury guidelines exhibit was updated by the United States Treasury on September 20, 2022. Accordingly, the legal guidance provided by NNDJ and Office of Legislative Counsel is modified to comply with the Treasury guidelines.

One such modification of legal guidance involved the processing of regional expenditure plans. Originally, the guidance was that all projects had to equal \$8,802,340 to be considered as completed and ready for legislative action. This guidance was modified in December 2022 to allow partial funding of the \$8,802,340 allocations so that proposed ARPA/NNFRF projects ready for legislative action could be processed by Office of Legislative Counsel. Because of the time constraints for the 24th Navajo Nation Council to act on proposed legislation, programs did not have sufficient time to provide written verification to Chapters regarding the change in legal guidance.

Pursuant to the authority vested in the Navajo Nation President, I am signing Resolution CD-70-22 into law.

THE NAVAJO NATION

JONATHAN NEZ | PRESIDENT MYRON LIZER | VICE PRESIDENT

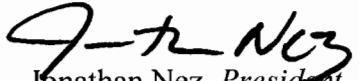

Sincerely,

Jonathan Nez, *President*
THE NAVAJO NATION

Myron Lizer, *Vice President*
THE NAVAJO NATION

RESOLUTION OF THE
NAVAJO NATION COUNCIL
24th NAVAJO NATION COUNCIL - FOURTH YEAR, 2022

AN ACTION

RELATING TO THE NAABIK'ÍYÁTI' COMMITTEE AND NAVAJO NATION COUNCIL;
APPROVING THE NAVAJO NATION FISCAL RECOVERY FUND DELEGATE REGION
PROJECT PLAN FOR HONORABLE EUGENE TSO'S DELEGATE REGION (CHAPTER:
CHINLE)

BE IT ENACTED:

SECTION ONE. AUTHORITY

- A. The Navajo Nation Council is the governing body of the Navajo Nation. 2 N.N.C. § 102(A).
- B. The Naabik'íyáti' Committee is a standing committee of the Navajo Nation Council with the delegated responsibility to hear proposed resolution(s) that require final action by the Navajo Nation Council. 2 N.N.C. § 164(A)(9).
- C. Navajo Nation Council Resolution No. CJN-29-22, incorporated herein by reference, mandates that Navajo Nation Fiscal Recovery Fund ("NNFRF") Delegate Region Project Plans be approved by Navajo Nation Council resolution and signed into law by the President of the Navajo Nation pursuant to 2 N.N.C. § 164(A) and 2 N.N.C. §§ 1005(C)(10), (11), and (12).

SECTION TWO. FINDINGS

- A. Navajo Nation Council Resolution No. CJN-29-22, AN ACTION RELATING TO THE NAABIK'ÍYÁTI' COMMITTEE AND NAVAJO NATION COUNCIL; ALLOCATING \$1,070,298,867 OF NAVAJO NATION FISCAL RECOVERY FUNDS; APPROVING THE NAVAJO NATION FISCAL RECOVERY FUND EXPENDITURE PLANS FOR: CHAPTER AND REGIONAL PROJECTS; PUBLIC SAFETY EMERGENCY COMMUNICATIONS, E911, AND RURAL ADDRESSING PROJECTS; CYBER SECURITY; PUBLIC HEALTH PROJECTS; HARDSHIP ASSISTANCE; WATER AND WASTEWATER PROJECTS; BROADBAND PROJECTS; HOME ELECTRICITY CONNECTION AND ELECTRIC CAPACITY PROJECTS; HOUSING PROJECTS AND MANUFACTURED HOUSING FACILITIES; BATHROOM ADDITION PROJECTS; CONSTRUCTION CONTINGENCY FUNDING; AND REDUCED ADMINISTRATIVE FUNDING, was signed into law by the President of the Navajo Nation on July 15, 2022.

- B. CJN-29-22, Section Three, states, in part and among other things, that:
1. The Navajo Nation hereby approves total funding for the NNFRF Chapter and Chapter Projects Expenditure Plan from the Navajo Nation Fiscal Recovery Fund in the total amount of two hundred eleven million two hundred fifty-six thousand one hundred forty-eight dollars (\$211,256,148) to be divided equally between the twenty-four (24) Delegate Regions in the amount of eight million eight hundred two thousand three hundred forty dollars (\$8,802,340) per Delegate Region . . . and allocated through Delegate Region Project Plans approved by Navajo Nation Council resolution and signed into law by the President of the Navajo Nation See CJN-29-22, Section Three (B).
 2. The Delegate Region Project Plan funding will be allocated to the Navajo Nation Central Government, specifically the Division of Community Development or other appropriate Navajo Nation Division or Department, to implement the projects rather than directly to the Chapters. See CJN-29-22, Section Three (D).
 3. The Navajo Nation Central Government, specifically the Division of Community Development or other appropriate Navajo Nation Division or Department, shall manage and administer funds and Delegate Region Project Plans on behalf of Non-LGA-Certified Chapters. The Navajo Nation Central Government may award funding to LGA-Certified Chapters through sub-recipient agreements to implement and manage specific projects, but shall maintain Administrative Oversight over such funding and Delegate Region Project Plans. See CJN-29-22, Section Three (E).
 4. Each Navajo Nation Council delegate shall select Fiscal Recovery Fund eligible projects within their Delegate Region to be funded by the NNFRF Chapter and Regional Projects Expenditure Plan through a Delegate Region Projects Plan. The total cost of projects selected by each Delegate shall not exceed their Delegate Region distribution of eight million eight hundred two thousand three hundred forty dollars (\$8,802,340). See CJN-29-22, Section Three (F).
 5. Each Delegate Region Project shall identify its Administrative Oversight entity and its Oversight Committee(s) and be subject CJY-41-21's NNDOJ initial eligibility determination. See CJN-29-22, Section Three (L) (5) and (L) (6).

- C. All projects listed in the Hon. Eugene Tso's Delegate Region Projects Plan, attached as Exhibit A, have been deemed Fiscal Recovery Fund eligible by NNDOJ. In addition, Hon. Eugene Tso's Delegate Region Projects Plan does not exceed the amount of \$8,802,340, as set forth in CJN-29-22, Section Three (F).
- D. The Navajo Nation Council hereby finds that it is in the best interest of the Navajo Nation and the Hon. Eugene Tso's Delegate Region Chapters and communities to approve and adopt the Navajo Nation Fiscal Recovery Fund Delegate Region Project Plan for Hon. Eugene Tso's Delegate Region (Chapter: Chinle) as set forth in Exhibit A.

SECTION THREE. APPROVAL OF HON. EUGENE TSO'S DELEGATE REGION PROJECT PLAN

- A. The Navajo Nation hereby approves the Fiscal Recovery Fund Delegate Region Project Plan for Hon. Eugene Tso's Delegate Region (Chapter: Chinle) set forth in Exhibit A.
- B. The Delegate Region Project Plan approved herein shall comply with all applicable provisions of CJY-41-21, CJN-29-22, and BFS-31-21.
- C. Any inconsistencies between this legislation, the Delegate Region Project Plan, and the individual project appendix, shall be resolved in favor of the project appendix reviewed by Department of Justice during their eligibility determination(s).

SECTION FOUR. AMENDMENTS

Amendments to this legislation or to the Delegate Region Project Plan approved herein shall only be adopted by resolution of the Navajo Nation Council and approval of the President of the Navajo Nation pursuant to 2 N.N.C. § 164(A)(17) and 2 N.N.C. §§ 1005(C)(10), (11), and (12).

SECTION FIVE. EFFECTIVE DATE

This legislation shall be effective upon its approval pursuant to 2 N.N.C. § 221(B), 2 N.N.C. § 164(A)(17), and 2 N.N.C. §§ 1005(C)(10), (11), and (12).

SECTION SIX. SAVING CLAUSE

If any provision of this legislation is determined invalid by the Navajo Nation Supreme Court, or by a Navajo Nation District Court without appeal to the Navajo Nation Supreme Court, those provisions

of this legislation not determined invalid shall remain the law of the Navajo Nation.

CERTIFICATION

I hereby certify that the foregoing resolution was duly considered by the 24th Navajo Nation Council at a duly called meeting in Window Rock, Navajo Nation (Arizona), at which a quorum was present and that the same was passed by a vote of 21 in Favor, and 00 Opposed, on this 29th day of December 2022.



Honorable Otto Tso, Speaker
24th Navajo Nation Council

12.30.2022

DATE

Motion: Honorable Jamie Henio
Second: Honorable Eugene Tso

Speaker Otto Tso not voting

ACTION BY THE NAVAJO NATION PRESIDENT:

1. I, hereby, sign into law the foregoing legislation, pursuant to 2 N.N.C. § 1005 (C)(10), on this 10th day of January, 2023.

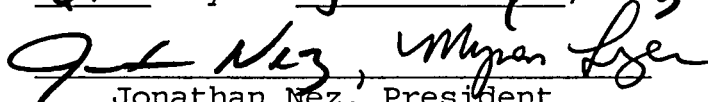
Jonathan Nez, President
Navajo Nation

2. I, hereby, veto the foregoing legislation, pursuant to 2 N.N.C. § 1005 (C)(11), on this _____ day of _____, 2022 for the reason(s) expressed in the attached letter to the Speaker.

Jonathan Nez, President
Navajo Nation

3. I, hereby, exercise line-item veto pursuant to the budget line-item veto authority delegated to the President by vote of the Navajo People in 2009, on this _____ day of _____, 2022.

Jonathan Nez, President
Navajo Nation

NAVAJO NATION FISCAL RECOVERY FUND DELEGATE REGION PROJECT PLAN

COUNCIL DELEGATE: Delegate Eugene Tso

CHAPTERS: Chinle

FUNDING RECIPIENT	SUBRECIPIENT	EXPENDITURE PLAN / PROJECT	ADMIN OVERSIGHT	FRF CATEGORY	DOJ REVIEW #	AMOUNT
Division of Community Development	*Chinle Chapter	Chinle Chapter Bathroom Additions Project	Division of Community Development	1.14	HK0207	\$ 1,725,000.00
Division of Community Development	*Chinle Chapter	Chinle Chapter Earth and Dam Project	Division of Community Development	2.22	HK0208	\$ 1,997,153.38
Division of Community Development	*Chinle Chapter	Chinle Chapter House Renovation Project	Division of Community Development	2.22	HK0209	\$ 800,000.00
Division of Community Development	*Chinle Chapter	Chinle Chapter South Manuelito Well Traffic Study	Division of Community Development	2.22	HK0210	\$ 15,000.00
Division of Community Development	*Chinle Chapter	Chinle Chapter Vendor Village Project	Rosanna Jumbo-Fitch, Chapter President	2.22	HK0211	\$ 37,743.62
Division of Community Development	*Chinle Chapter	Chinle Chapter and Office of Dine Youth	Rosanna Jumbo-Fitch, Chapter President	2.14	HK0212	\$ 50,000.00
Division of Community Development	*Chinle Chapter	Chinle Chapter CYEP and PEP Funding	Division of Community Development	1.14	HK0213	\$ 1,150,953.00
Division of Community Development	*Chinle Chapter	Chinle Chapter Watering Point Pavement Project	Division of Community Development	5.15	HK0214	\$ 70,000.00
Division of Community Development	*Chinle Chapter	Chinle Chapter Warehouse	Division of Community Development	6.1	HK0270	\$ 1,200,000.00
Division of Community Development	*Chinle Chapter	Chinle/Ft. Defiance Alcohol and Substance Abuse Recovery Centers - Day At A Time Club, Inc.	NN Department of Health	1.13	HK0203	\$ 250,000.00
TOTAL:						\$ 7,295,850.00

*Per CJN-29-22, Section Three (E), the "Navajo Nation Central Government may award funding to LGA-Certified Chapters through sub-recipient agreements to implement and manage specific projects, but shall maintain Administrative Oversight over such funding and Delegate Region Project Plans."

NAVAJO NATION FISCAL RECOVERY FUND DELEGATE REGION PROJECT PLAN

COUNCIL DELEGATE: Delegate Eugene Tso

CHAPTERS: Chinle

FUNDING RECIPIENT	SUBRECIPIENT	EXPENDITURE PLAN / PROJECT	ADMIN OVERSIGHT	FRF CATEGORY	DOJ REVIEW #	AMOUNT
		TOTAL AMOUNT from PAGE 01				\$ 7,295,850.00
Division of Community Development	*Chinle Chapter	Chinle Chapter Equipment Project	Chinle Chapter Government	6.1	HK0268	\$ 288,500.00
Division of Community Development	*Chinle Chapter	Chinle Chapter Wellness Center	Division of Community Development	2.22	HK0269	\$ 750,000.00
Division of Community Development	*Chinle Chapter	Chinle Chapter Emergency Funding	Division of Community Development	6.1	HK0276	\$ 250,500.00
Division of Community Development	*Chinle Chapter	Chinle Chapter N8095 Road Crossing Project	NN Division of Transportation	2.22	HK0274	\$ 217,490.00
		UN-ALLOCATED AMOUNT				
TOTAL:						\$ 8,802,340.00

*Per CJN-29-22, Section Three (E), the "Navajo Nation Central Government may award funding to LGA-Certified Chapters through sub-recipient agreements to implement and manage specific projects, but shall maintain Administrative Oversight over such funding and Delegate Region Project Plans."



NAVAJO NATION DEPARTMENT OF JUSTICE
OFFICE OF THE ATTORNEY GENERAL

DOREEN N. MCPAUL
Attorney General

KIMBERLY A. DUTCHER
Deputy Attorney General

DEPARTMENT OF JUSTICE
INITIAL ELIGIBILITY DETERMINATION
FOR NAVAJO NATION FISCAL RECOVERY FUNDS

RFS/HK Review #: HK0212

Date & Time Received: 11/15/22

Date & Time of Response: 11/28/2022 5:00 PM

Entity Requesting FRF: Chinle Chapter Government

Title of Project: Chinle Chapter and Office of Dine Youth

Administrative Oversight: Chapter President - Dr. Rosanna Jumbo-Fitch

Amount of Funding Requested: \$50,000

Eligibility Determination:

- FRF eligible
FRF ineligible
Additional information requested

FRF Eligibility Category:

- (1) Public Health and Economic Impact
(2) Premium Pay
(3) Government Services/Lost Revenue
(4) Water, Sewer, Broadband Infrastructure

U.S. Department of Treasury Reporting Expenditure Category: 2.14 (Healthy Childhood Environments: Early Learning)

Returned for the following reasons (Ineligibility Reasons / Paragraphs 5. E. (1) - (10) of FRF Procedures):

- | | |
|--|--|
| <input type="checkbox"/> Missing Form | <input type="checkbox"/> Expenditure Plan incomplete |
| <input type="checkbox"/> Supporting documentation missing | <input type="checkbox"/> Funds will not be obligated by 12/31/2024 |
| <input type="checkbox"/> Project will not be completed by 12/31/2026 | <input type="checkbox"/> Incorrect Signatory |
| <input type="checkbox"/> Ineligible purpose | <input type="checkbox"/> Inconsistent with applicable NN or federal laws |
| <input type="checkbox"/> Submitter failed to timely submit CARES reports | |
| <input type="checkbox"/> Additional information submitted is insufficient to make a proper determination | |

Other Comments: _____

Name of DOJ Reviewer: Kristen A. Lowell

Signature of DOJ Reviewer: 

Disclaimers: This Initial Eligibility Determination is based on the documents provided which we have assumed are true, correct, and complete. Should the Project or Program change in any material way after this initial determination, the requestor must seek the advice of NNDOJ. This initial determination is limited to review of the Project or Program as it relates to whether the Project or Program is a legally allowable use – it does not serve as an opinion as to whether or not the Project or Program should be funded, nor does it serve as an opinion as to whether or not the amount requested is reasonable or accurate.

**THE NAVAJO NATION
FISCAL RECOVERY FUNDS REQUEST FORM & EXPENDITURE PLAN
FOR GOVERNANCE-CERTIFIED CHAPTERS**

Part 1. Identification of parties.

Governance-Certified Chapter requesting FRF: Chinle Chapter Government Date prepared: 10-19-2022

Chapter's mailing address: PO BOX 1809
Chinle, AZ 86503 phone & email: (928) 674-2052
website (if any): chinle@navajochapters.org

This Form prepared by: Dr. Rosanna Jumbo-Fitch phone/email: (928) 225-1658
Chinle Chapter President rosanna.jumbo@naataanii.org
CONTACT PERSON'S name and title CONTACT PERSON'S info

Title and type of Project: Chinle Chapter and Office of Dine Youth

Chapter President: Dr. Rosanna Jumbo-Fitch phone & email: (928) 225-1658/rosanna.jumbo@naataanii.org

Chapter Vice-President: Shawna Claw phone & email: (928) 674-2052/sclaw@navajochapters.org

Chapter Secretary: Roann Burbank phone & email: (928) 674-2052/rburbank@navajochapters.org

Chapter Treasurer: Roann Burbank phone & email: (928) 674-2052/rburbank@navajochapters.org

Chapter Manager or CSC: Walton Yazzie, Manager phone & email: (505)910-9473/wyazzie@navajochapters.org

DCD/Chapter ASO: _____ phone & email: _____

List types of Subcontractors or Subrecipients that will be paid with FRF (if known): Not known

document attached

Amount of FRF requested: 50,000.00 FRF funding period: 2023-2026 10/1/23-9/30/25
indicate Project starting and ending/deadline date

Part 2. Expenditure Plan details.

(a) Describe the Program(s) and/or Project(s) to be funded, including how the funds will be used, for what purposes, the location(s) to be served, and what COVID-related needs will be addressed:

Chinle Chapter Government would assist the Office of Dine Youth in securing funds to complete ODY, Chinle, AZ building upgrades. The funds will be used for a new shower installation, new 40'X9' storage building, new utility sink, and PPE materials and equipment. The Office of Dine Youth will continue to serve those that are currently assisted through the Chinle Office of Dine Youth program.

document attached

(b) Explain how the Program or Project will benefit the Navajo Nation, Navajo communities, or the Navajo People:

The Chinle Chapter and Chinle Office of Dine Youth program will benefit the Navajo Nation, surrounding Navajo communities, and Navajo people through added plumbing, added storage, and added PPE supplies.

document attached

(c) A prospective timeline showing the estimated date of completion of the Project and/or each phase of the Project. Disclose any challenges that may prevent you from incurring costs for all funding by December 31, 2024 and/or fully expending funds and completing the Program(s) or Project(s) by December 31, 2026:

Chinle Chapter Government ODY Project timeline: Chinle Chapter resolution 10/17/2022, Navajo Nation and DOJ review submissions Winter 2022, Purchases Spring 2023- Fall 2023. Construction would be an estimated 6 months. Challenges would include Navajo Nation review timeline.

document attached

(d) Identify who will be responsible for implementing the Program or Project:

Chinle Chapter Government will be responsible for implementing the project and assistance.

document attached

(e) Explain who will be responsible for operations and maintenance costs for the Project once completed, and how such costs will be funded prospectively:

The Office of Dine Youth will be responsible for operations and maintenace costs for the project once completed.

document attached

(f) State which of the 66 Fiscal Recovery Fund expenditure categories in the attached U.S. Department of the Treasury Appendix 1 listing the proposed Program or Project falls under, and explain the reason why:

Healthy Childhood Environments: Early Learning*^ 2.14

Chinle Chapter is seeking funding for the Office of Dine Youth, Chinle AZ. The items include plumbing upgrades, storage additions, and overall PPE supplies.

document attached

Part 3. Additional documents.

List here all additional supporting documents attached to this FRF Expenditure Plan (or indicate N/A):

Chapter Resolution is attached, ODY budget, and ODY Manager email with clarifications on Scope of Work.

Chapter Resolution attached

Part 4. Affirmation by Funding Recipient.

Funding Recipient affirms that its receipt of Fiscal Recovery Funds and the implementation of this FRF Expenditure Plan shall be in accordance with Resolution No. CJY-41-21, the ARPA, ARPA Regulations, and with all applicable federal and Navajo Nation laws, regulations, and policies:

Chapter's Preparer: Rosanna Jumbo-Fitch
signature of Preparer/CONTACT PERSON

Approved by: Rosanna Jumbo-Fitch
signature of Chapter President (or Vice-President)

Approved by: [Signature]
signature of Chapter Manager or CSC

Approved by: _____
signature of DCD/Chapter ASO

Approved to submit for Review: [Signature]
signature of DCD Director

FY 2023

THE NAVAJO NATION
PROGRAM BUDGET SUMMARY

Page 1 of 4
BUDGET FORM 1

PART I. Business Unit No.: <u>New</u>		Program Title: <u>Chinle Office of Dine Youth</u>		Division/Branch: <u>DCD / Executive Branch</u>	
Prepared By: <u>Walton Yazzie</u>		Phone No.: <u>928.674.2052</u>		Email Address: <u>wyazzie@nnchapters.org</u>	
PART II. FUNDING SOURCE(S)	Fiscal Year / Term	Amount	% of Total	PART III. BUDGET SUMMARY	
NN Fiscal Recovery Funds	FY 23-FY25 <u>10/1/23-9/30/25</u>	50,000.00	100%	Fund Type Code	(A) NNC Original Budget
					(B) Proposed Budget
					(C) Difference or Total
				2001 Personnel Expenses	
				3000 Travel Expenses	
				3500 Meeting Expenses	
				4000 Supplies	
				5000 Lease and Rental	
				5500 Communications and Utilities	
				6000 Repairs and Maintenance	
				6500 Contractual Services	
				7000 Special Transactions	
				8000 Public Assistance	50,000
				9000 Capital Outlay	
				9500 Matching Funds	
				9500 Indirect Cost	
				TOTAL	\$0.00
				TOTAL	50,000.00
PART IV. POSITIONS AND VEHICLES				(D)	(E)
				Total # of Positions Budgeted:	2
				Total # of Vehicles Budgeted:	0
				TOTAL	2
				TOTAL	0

PART V. I HEREBY ACKNOWLEDGE THAT THE INFORMATION CONTAINED IN THIS BUDGET PACKAGE IS COMPLETE AND ACCURATE.

SUBMITTED BY: Walton Yazzie APPROVED BY: Lisa Jymm
 Program Manager's Printed Name Division Director / Branch Chief's Printed Name
[Signature] 10/24/22 [Signature]
 Program Manager's Signature and Date Division Director / Branch Chief's Signature and Date

THE NAVAJO NATION
 PROGRAM PERFORMANCE CRITERIA

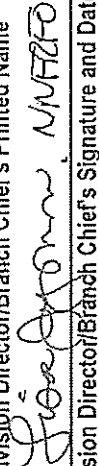
PART I. PROGRAM INFORMATION:		Chinle Office of Dine Youth								
Business Unit No.:	New	Program Name/Title:								
PART II. PLAN OF OPERATION/RESOLUTION NUMBER/PURPOSE OF PROGRAM:										
PART III. PROGRAM PERFORMANCE CRITERIA:										
1. Goal Statement:	install showers and other related work duties		1st QTR		2nd QTR		3rd QTR		4th QTR	
Program Performance Measure/Objective:	Hire two (2) Maintenance Technicians		Goal	Actual	Goal	Actual	Goal	Actual	Goal	Actual
2. Goal Statement:	Safer place to work				2					
Program Performance Measure/Objective:	Purchase PPE supplies						1			
3. Goal Statement:	Need a place to store PPE supplies									
Program Performance Measure/Objective:	Purchase a Storage box						1			
4. Goal Statement:										
Program Performance Measure/Objective:										
5. Goal Statement:										
Program Performance Measure/Objective:										
PART IV. I HEREBY ACKNOWLEDGE THAT THE ABOVE INFORMATION HAS BEEN THOROUGHLY REVIEWED.										
		Walton Yazzie		Lisa Jymm						
Program Manager's Printed Name		Walton Yazzie		Division Director/Branch Chief's Printed Name						
		6.0.24.22								
Program Manager's Signature and Date		6.0.24.22		Division Director/Branch Chief's Signature and Date						

PART I. PROGRAM INFORMATION: Program Name/Title: <u>Chinle Office of Dine Youth</u> Business Unit No.: <u> </u> New			
PART II. DETAILED BUDGET:			
(A)	(B)	(C)	(D)
Object Code (LOD 6)	Object Code Description and Justification (LOD 7)	Total by DETAILED Object Code (LOD 6)	Total by MAJOR Object Code (LOD 4)
8000	Assistance		50,000
8705	Chapter		
8710	PEP	32,854	
8740	Emergency	17,146	
	Complete Chinle OBY building upgrades and assist youth in the community.		
TOTAL		50,000	50,000

**THE NAVAJO NATION
PROJECT BUDGET SCHEDULE**

<p>PART I. Business Unit No.: <u>New</u></p> <p>Project Title: <u>Chinle Office Dine Youth</u></p> <p>Project Description <u>Redo the restrooms, storage area, and PPE supplies</u></p> <p>Check one box: <input checked="" type="checkbox"/> Original Budget <input type="checkbox"/> Budget Revision <input type="checkbox"/> Budget Reallocation <input type="checkbox"/> Budget Modification</p>	<p>PART II. Project Information</p> <p>Project Type: <u>Chinle Office of Dine Youth</u></p> <p>Planned Start Date: <u>10/1/2022</u></p> <p>Planned End Date: <u>9/30/2025</u></p> <p>Project Manager: <u>Walton Yazzie</u></p>
--	---

PART III. List Project Task separately; such as Plan, Design, Construct, Equip or Furnish.	PART IV. Use Fiscal Year (FY) Quarters to complete the information below. O = Oct.; N = Nov.; D = Dec., etc.																Expected Completion Date if project exceeds 8 FY Qtrs.	
	FY <u>2023</u>																	
	1st Qtr.		2nd Qtr.		3rd Qtr.		4th Qtr.		1st Qtr.		2nd Qtr.		3rd Qtr.		4th Qtr.			
	O	N	D	J	F	M	A	M	J	Jul	A	S	O	N	D	J	F	M
Hire two (2) Maintenance Technicians																		
Purchase PPE supplies	X	X		X	X	X												
Purchase a storage box					X													
PART V.																		
Expected Quarterly Expenditures	\$		\$		\$		\$		\$		\$		\$		\$		PROJECT TOTAL	
			33,873.20		16,426.80												\$50,000.00	

Chinle Chapter Government

THE NAVAJO NATION

Dr. Rosanna Jumbo-Fitch
PRESIDENT

Shawna Claw
VICE PRESIDENT

RoAnn Burbank
SECRETARY/TREASURER

Eugene Tso
COUNCIL DELEGATE

Oscar Bia
GRAZING COMMITTEE MEMBER

RESOLUTION OF THE CHINLE CHAPTER NAVAJO NATION CHIN-OCT-22-083

APPROVING THE SELECTION OF THE CHAPTER OFFICE OF DINE YOUTH PROJECT FOR THE INCLUSION ON THE CHINLE CHAPTER DELEGATE REGION IN THE AMOUNT OF \$50,000.00.

WHEREAS:

1. Pursuant to Navajo Nation Code, Section 4001 (d) and 4028 (2), (b) the Chinle Chapter is established and certified as a local government entity of the Navajo Nation, vested with the authority to review all matters affecting the chapter and submit appropriate recommendations to the Navajo Nation government of other local agencies by resolutions; and
2. To support the efforts of the Navajo Nation to mitigate the effects of the COVID-19 Pandemic, the American Rescue Plan Act (ARPA) Fiscal Recovery Funds were allocated to develop the basic infrastructure to improve lives of people who have lived without water, electricity and "basic services to support their daily activities, health, and welfare"; and
3. The Navajo Nation Council approved CIN-29-22, in response to the COVID-19 Pandemic in the best interest of the people: "An Action Relating to the Naabik'iyati' Committee and Navajo Nation Council; Allocating \$1,070,298,867 of Navajo Nation Fiscal Recovery Funds; Approving the Navajo Nation Fiscal Recovery Fund Expenditure Plans for: Chapter Assistance; Public Safety Emergency Communications, E911, and Rural Addressing Projects; Cyber Security; Public Health Projects; Economic Development Projects; Hardship Assistance; Water and Wastewater Projects; Broadband Projects; Home Electricity Connection and Electricity Capacity Projects; Housing Projects and Manufactured Housing Facilities; Bathroom Addition Projects; Construction Contingency Funding; and Reduced Administrative Funding"; and
4. The Chinle Chapter Government has attended several meetings with Navajo Nation Division of Community Development, Navajo Tribal Utility Authority, and the Fiscal Recovery Fund Office; and
5. The eligible attached Exhibit: Chinle Chapter Office of Dine Youth was selected as a Project to be included on the Navajo Nation Council Delegate Eugene Tso Chapter Region in the amount of \$50,000.00 for the Chinle Chapter; and
6. The total amount for Chinle Chapter Delegate Region is \$8,502,340.00.

NOW, THEREFORE BE IT RESOLVED THAT:

1. The Chinle Chapter Government hereby approves the selection of Chinle Chapter Office of Dine Youth was a selected Project to be included on the Navajo Nation Council Delegate Eugene Tso Chapter Region in the amount of \$50,000.00.

CERTIFICATION

We hereby certify that the foregoing chapter resolution was duly considered by the Chinle Chapter at a duly called meeting at which time a quorum was present. A motion was made by Oscar Bia Sr. and seconded by Walton Yazzie and the same was passed by a vote of 7 in favor, 0 opposed, and 3 abstained, this 17th day of October, 2022.

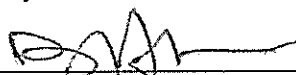

Dr. Rosanna Jumbo-Fitch, President



Shawna Claw, Vice Presidents



RoAnn Burbank, Secretary/Treasurer

PO Box 1809 Chinle, Arizona
86503

• P: (928) 674-2052 • F: (928) 674-2079 • chinle@navajochapters.org

ODY

Al Tsedah <altsedah@yahoo.com>

Thu, Oct 20, 2022 at 1:56 PM

To: Walton Yazzie <wyazzie@nnchapters.org>, Rosanna Jumbo <rosanna.jumbo@naataanii.org>

The personnel positions will complete installation of shower stalls and drainage sink. The scope of work is to complete the project within 6-months.

The showers are to be use by the youth participants during any activity provided by Office of Dine Youth. Today, our youth participants sometimes would execute an accident (meaning: dirty themselves) and need attention to clean themselves quickly through taking a shower. Not all youth participants have access to running wafer or plumbing at their home, and when they participate in our physical activities, some will need to cleanse themselves before going home. Our promotion is always, self-care through washing up and keep hygienically sanitized.

The drainage sink at the Boys & Girls Club is much needed. Right now, there is not drainage sink for any janitorial related cleaning, most time water is drained outside of the building. With this installation, a lot more and improvement of draining of dirty used water can be drained in doors. The Club will be in compliance with OEH standards as well. Drainage sink is much essential to clean, sanitize, and mop as everyday general cleaning.

The storage is desired to safe keep all our essentials, our recreation equipment & supplies, our personal protective equipment & supplies. We stopped partnering up with other entities on getting cleaning and sanitation supplies to distribute to our youth during Covid19 era, because we have no storage to safeguard the supplies. The storage will help tremendously to keep our cleaning supplies fresh to distribute and to keep our equipment safe.

The PPE will be purchased to continue to distribute to our youth within our areas (agency) to keep them safe from any disease contractions.

Thank you, and hope this helps..

Al Tsedah

[Quoted text hidden]

ODY \$ 50,000.00
BUDGET for NEEDS IMPROVEMENT

I.	PERSONNEL	32,853.60
	To hire (2) Maintenance Technicians at entry level pay to do plumbing work. Install janitorial sink and shower stalls. Maintenance Technicians will perform journey level skilled repair and maintenance work in any of several trades such as plumbing, carpentry, painting, building maintenance, and appliances repair and maintenance; will perform related work as assigned.	
	$\$15.63 \times 960 \text{ hours} \times 2 = \$ 30,009.60$	
	$30,009.60 \times 9.48\% = 2,844.00$	
	TOTAL: \$ 32,853.60	
II	IMPROVEMENT PROJECTS: INSTALL SHOWERS & SINK	3,519.40
	Listing of supplies and installation kits are included in the packet.	
III	STORAGE BOX	10,000.00
	Storage is needed to store PPE supplies and other regularly used equipment, such as recreational equipment, tent, canopies, tables, chairs, etc. Safe keeping of these items is necessary and much in need.	
IV	MEDICAL SUPPLIES/PPE	3,627.00
	Will purchase cleaning supplies, sanitizers, disinfect wipes, personal hygienes, facial mask, etc. to keep for office cleaning and to distribute to youth at all ODY events as part of prmoting and encouraging safety and prevention.	
	GRAND TOTAL:	\$50,000.00

Please accept the forthgoing budget of the \$50,000.00 requested from Office of Dine YOUTH as part of ARPA funding distribution to the Chapter. Our request was was approved at your Chapter Meeting through a resolution. Thank you.

Submitted by:

Al Tsedah, Program Supervisor III

Chnle ODY/BGC - Chinle Agency

928-674-2066

Your Cart (12)

[Share](#)

[Remove All Items](#)

[Checkout](#)

FREE Shipping on eligible items. [View Details](#)

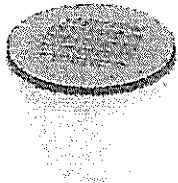

OATEY Round Gray PVC Shower Drain with 4-1/4 in. Round Snap-In Stainless Steel Drain Cover

Model #420452

\$20.76

(\$10.38/item)

2

Store Pickup
18 in stock at
Gallup
87301

FREE

Ship To Home
Order within 6 hrs 17 mins get it by Mon, Oct 17

FREE

Scheduled Delivery
Starting at \$8.99 for delivery as soon as today

[How It Works](#)

[Save for Later](#) [Save to Favorites](#) [Remove](#)

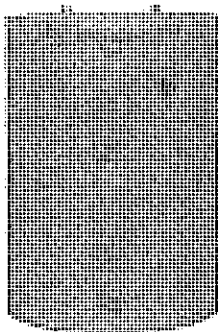

Rheem Performance 30 Gal. Short 6 Year 4500/4500-Watt Elements Electric Tank Water Heater

Tank Warranty: 6 Year
Nominal Tank Capacity (gallons)

\$519.00

Ship To Store
Oct. 21-Oct. 26
Gallup
87301

FREE

Ship To Home
Estimated Arrival:
Fri, Oct 28

\$55.00

Scheduled Delivery
Starting at \$8.99 for delivery as soon as today

[How It Works](#)

Add a Home Depot Protection Plan by Allstate?
5-year Protection for \$69.00

[Learn More](#)

[Save for Later](#) [Save to Favorites](#) [Remove](#)

Mueller Streamline 1/2 in. x 10 ft. Copper Type L Pipe

Model #LH04010

\$46.52

(\$23.26/item)

Get Bulk Pricing of \$18.61 on this item when you purchase at least 10 units.

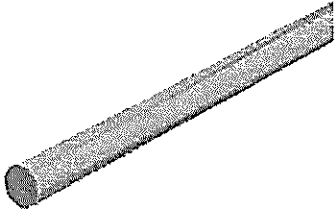

2

Store Pickup
22 in stock at
Gallup
87301 | Change

FREE

Ship To Home

Scheduled Delivery
Starting at \$8.99 for delivery as soon as tomorrow

How It Works

Curbside Available

Save for Later Save to Favorites Remove

SnappyTrap 1-1/2 in. All-in-One Drain Kit for Single Bowl Kitchen Sinks, Bar Sinks and Utility Sinks

Model #DK-100

\$17.84

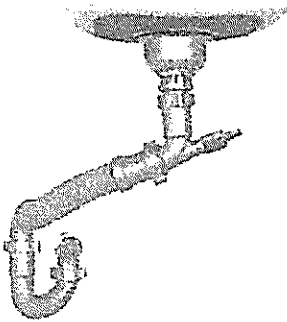

1

Store Pickup
10 in stock at
Gallup
87301

FREE

Ship To Home
Order within 6 hrs 17 mins get it by Mon, Oct 17

FREE

Scheduled Delivery
Starting at \$8.99 for delivery as soon as tomorrow

How It Works

Save for Later Save to Favorites Remove

MOEN Adler Single-Handle 4-Spray Shower Faucet in Chrome (Valve Included)

Model #82604

\$178.00

(\$89.00/item)

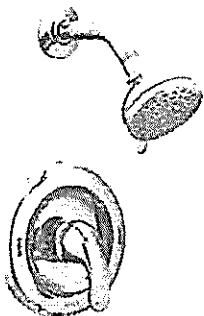

2

Store Pickup
12 in stock at
Gallup
87301

FREE

Ship To Home
Order within 6 hrs 17 mins get it by Mon, Oct 17

FREE

Scheduled Delivery
Starting at \$8.99 for delivery as soon as today

How It Works

Save for Later Save to Favorites Remove



TEHILA Complete 22.875 in. x 23.5 in. White 19 Gal. Utility Sink Set with Black Metal Hybrid Faucet and Soap Dispenser

Model #040 US6507

\$233.30



1

Ship To Store
Oct. 18–Oct. 20
Gallup
87301 | Change

FREE

Ship To Home

FREE

Scheduled Delivery
Not Available for this item

Curbside Available

Save for Later Save to Favorites Remove

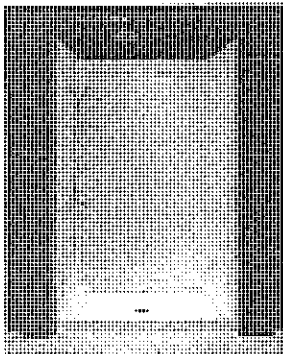

DreamLine SlimLine 48 in. x 32 in. Single Threshold Shower Base in White with Shower Backwalls

Model #DL-6070C-01

\$2,379.98

(\$1,189.99/item ~~\$1,252.75~~)

Save 5%

2

Ship To Store
Oct. 25–Oct. 28
Gallup
87301 | Change

FREE

Ship To Home

Scheduled Delivery
Not Available for this item

Curbside Available

Subtotal	\$3,589.92
Savings	-\$125.52
Estimated Shipping*	\$55.00
Pick Up In Store	FREE
Sales Tax (determined in later step)	---
Total	\$3,519.40

You Saved 3% Off Your Items

Have a promo code?

* Shipping and delivery charges are calculated at the lowest rate available. Other methods will be viewable on the next page.

Checkout

— or —



Easy In-Store and Online Returns

Read our Return Policy

Customers Also Purchased...

Best Seller



BrassCraft 3/8 In. Compression x 1/2 in. FIP x 20 in.

~~\$7.29~~
\$7

Add To Cart

Exclusive



BrassCraft 3/8 In. Compression x 7/8 in. Ballcock Nut x

~~\$3.43~~
\$3

Add To Cart



Everbilt 1-1/2 in. White Plastic Sink Drain P-Trap with

(70)

~~\$4.94~~
\$4.94

Add To Cart



Glacier Bay All-in-One 24 in. x 24 in. 20 Gal.

~~\$106.00~~
\$149

Add To Cart

Best Seller



SnappyTrap Universal Drain Kit for Bathroom

(716)

~~\$15.78~~
\$15.78

Add To Cart



Fluidmaster Better Than Wax Universal Wax-

~~\$12.53~~
\$9.99

Add To Cart



SharkBri Push-In 3/8 in.

~~\$12.45~~
\$12.45

Add To Cart

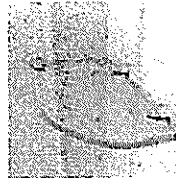
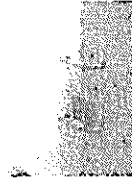
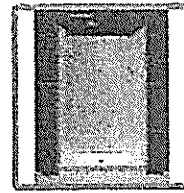
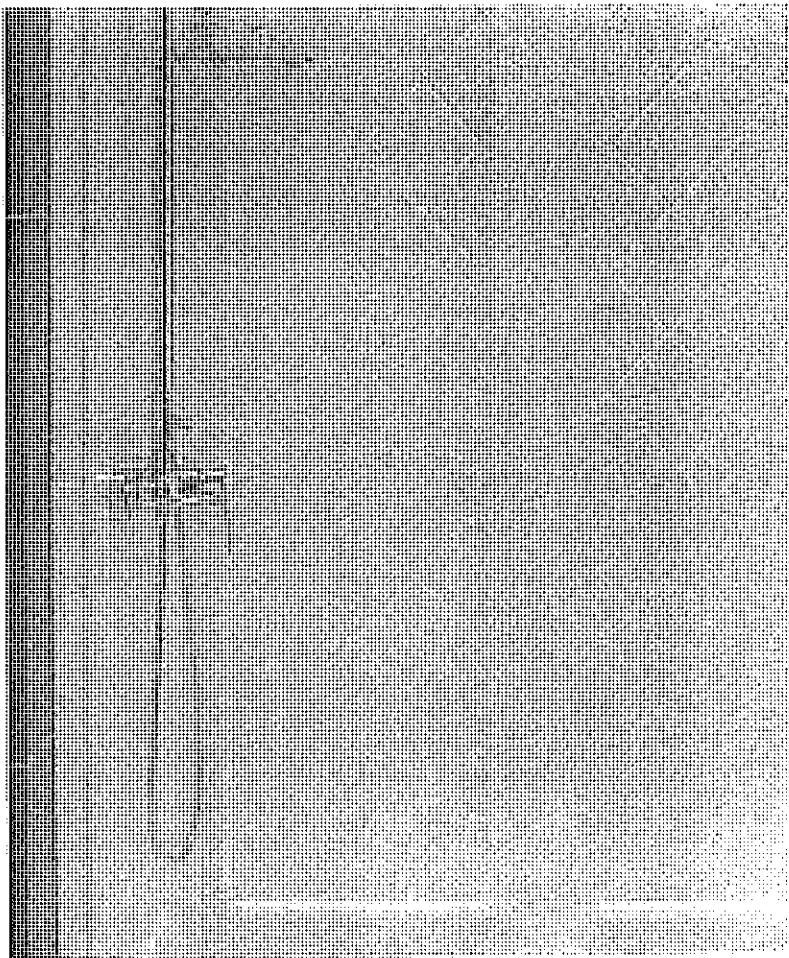

Close X

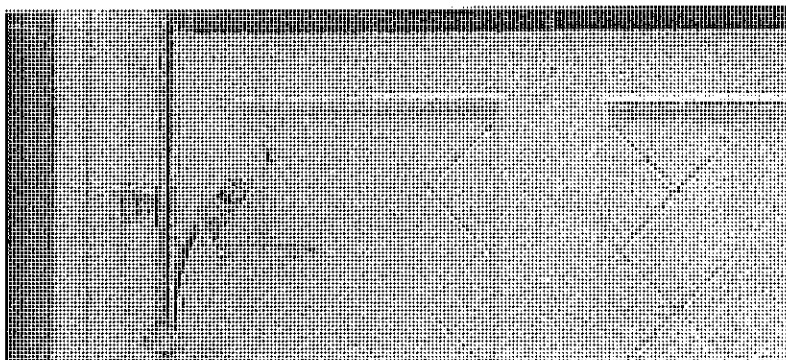

SlimLine 48 in. x 32 in.
Single Threshold Shower
Base in White with
Shower Backwalls

by DreamLine

Product Images

Feedback

Live Chat

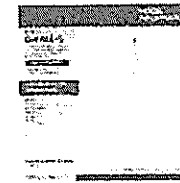
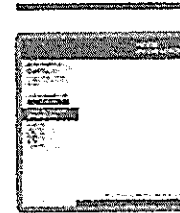
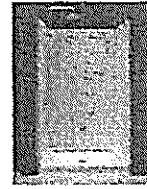
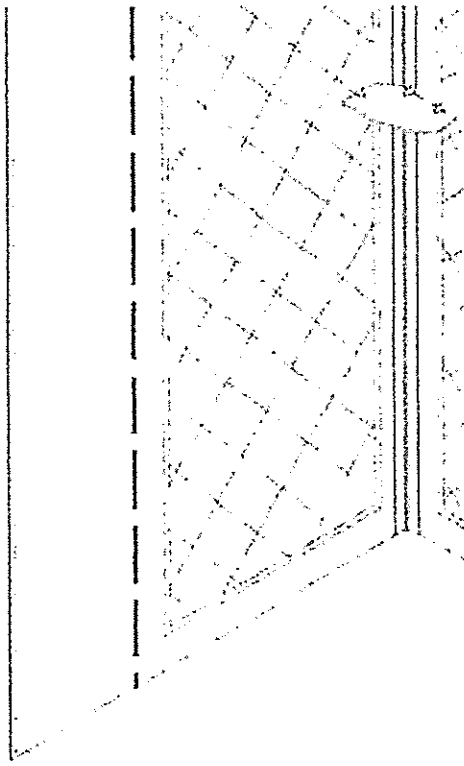
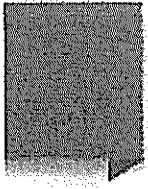

Close X

SlimLine 48 in. x 32 in.
Single Threshold Shower
Base in White with
Shower Backwalls

by DreamLine

Product Images

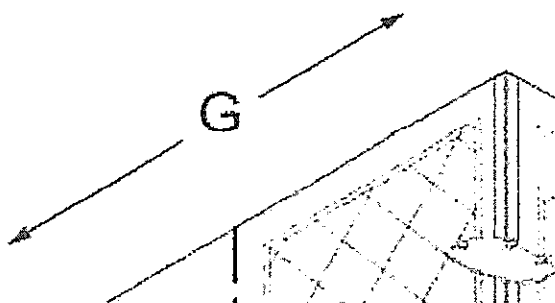

Live Chat

Feedback

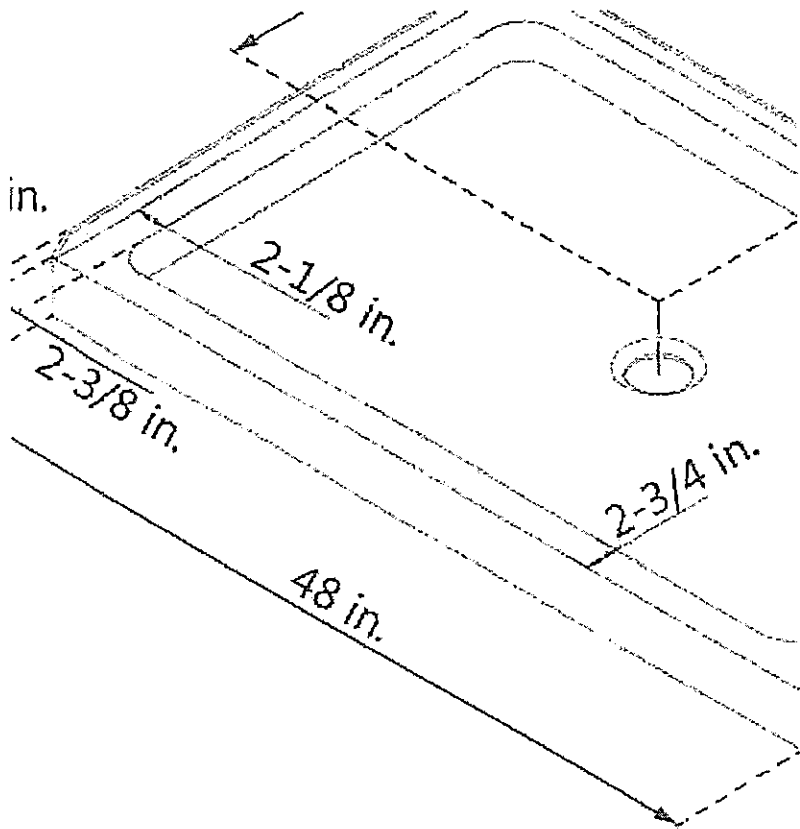

DreamLine reserves

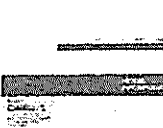
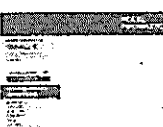
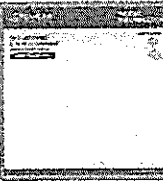
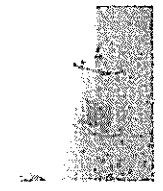
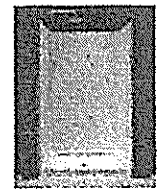

Close X



SlimLine 48 in. x 32 in.
Single Threshold Shower
Base in White with
Shower Backwalls

by DreamLine

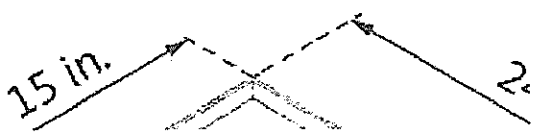

Product Images

Feedback Live Chat

MAINTENANCE TECHNICIAN

DEFINITION: Under general supervision, performs journey level skilled repair and maintenance work in any of several trades such as plumbing, carpentry, painting, building maintenance, and appliance repair and maintenance; performs related work as assigned.

ESSENTIAL FUNCTIONS: This list is ILLUSTRATIVE ONLY and is not a comprehensive listing of all functions and tasks performed by incumbents of this class.

TASKS:

Performs general maintenance and carpentry and cabinet-making work; installs cabinets and shelves; frames walls; repairs and replaces doors, windows, casing, garage doors, roof and carpet; installs flooring; performs plumbing activities, installing new plumbing including pipes, drains, tubs, faucets, sinks, and other plumbing fixtures and equipment; makes repairs on old plumbing; repairs breaks; replaces washers and valves; clean and opens drains and water lines; performs painting activities by preparing surface to be painted including sanding, scraping, patching, priming and texturing surfaces, mixes and applies paints to surfaces; mixes and applies plaster.

Performs installation, alteration, maintenance and repair of wiring systems and electrical fixtures and equipment; replace fuses, bulbs and globes; maintains, repairs or replaces residential type appliance such as water coolers, refrigerators, etc.; maintains, repairs or replaces heating ventilation and air conditioning units; checking Freon pressure; removes or recycles refrigerant; inspects fans, condensers, blower motors, heating and cooling units, wiring, etc.; services common household appliances; inspects damage to determine scope of work; estimates materials and supplies needed to complete work; re-keys and masters all locks; cleans and repairs tools and equipment.

Performs on call emergency duties for major outages, sewer backups, etc; provides cross training for co-workers and acquires cross training in other trades areas; installs security alarm systems; winterizes and summarizes heating units and air conditioners; provides preventive maintenance and troubleshooting; locates gas or water leaks; checks units for proper operation; performs preventive maintenance program through scheduled inspection and servicing of equipment, housing and facilities; maintains a clean and safe work environment.

KNOWLEDGE, SKILLS AND OTHER CHARACTERISTICS:

Knowledge of common practices, methods, materials and tools of various journey level building, electrical, and plumbing trades.

Knowledge of National Electric Code, Plumbing Code, Building Code and Plumbing Code.

Knowledge of hazards and safety precautions of various trades.

Knowledge of power and technical tool operation related to appliance repair and maintenance.

Knowledge of installation and programming of security alarm systems.

Knowledge of occupational safety and health regulations and practices.

Skill in troubleshooting and repairing a variety of commercial and residential appliances.

Skill in performing semi-skilled tasks of various trades.

Skill in safely working with potentially hazardous materials, chemicals and supplies.

Skill in prioritizing and handling multiple assignments.

Skill in maintaining and repairing power and hand tools and equipment.

Skill in establishing and maintaining effective working relationships.

Skill in welding.

MAINTENANCE TECHNICIAN

Ability to read and work from blueprints, shop drawings and sketches.
Ability to learn relevant building, fire and safety codes.

PHYSICAL REQUIREMENTS AND WORK ENVIRONMENT: Work requires extended hours working, lifting, carrying and transporting heavy tools, appliances, material and equipment weighing in excess of 100 pounds; requires climbing, kneeling, bending stooping and working in confined spaces.

MINIMUM QUALIFICATIONS:

- A high school diploma/GED; and three (3) years of general building maintenance experience in one or more trades area; or an equivalent combination of education and experience.

Special Requirements:

- Possess a valid state driver's license.

PREFERRED QUALIFICATIONS:

- Journeyman level certification
- Occupational Safety and Health Administration training.
- HVAC training or certification.

Supplemental Requirements:

Incumbent must obtain a Navajo Nation Vehicle Operator's Permit within 90 days of date of hire.

Depending upon the needs of the Nation, some incumbents of the class may be required to demonstrate fluency in both the Navajo and English languages as a condition of employment.

MAINTENANCE TECHNICIAN

DEFINITION: Under general supervision, performs journey level skilled repair and maintenance work in any of several trades such as plumbing, carpentry, painting, building maintenance, and appliance repair and maintenance; performs related work as assigned.

ESSENTIAL FUNCTIONS: This list is ILLUSTRATIVE ONLY and is not a comprehensive listing of all functions and tasks performed by incumbents of this class.

TASKS:

Performs general maintenance and carpentry and cabinet-making work; installs cabinets and shelves; frames walls; repairs and replaces doors, windows, casing, garage doors, roof and carpet; installs flooring; performs plumbing activities, installing new plumbing including pipes, drains, tubs, faucets, sinks, and other plumbing fixtures and equipment; makes repairs on old plumbing; repairs breaks; replaces washers and valves; clean and opens drains and water lines; performs painting activities by preparing surface to be painted including sanding, scraping, patching, priming and texturing surfaces, mixes and applies paints to surfaces; mixes and applies plaster.

Performs installation, alteration, maintenance and repair of wiring systems and electrical fixtures and equipment; replace fuses, bulbs and globes; maintains, repairs or replaces residential type appliance such as water coolers, refrigerators, etc.; maintains, repairs or replaces heating ventilation and air conditioning units; checking Freon pressure; removes or recycles refrigerant; inspects fans, condensers, blower motors, heating and cooling units, wiring, etc.; services common household appliances; inspects damage to determine scope of work; estimates materials and supplies needed to complete work; re-keys and masters all locks; cleans and repairs tools and equipment.

Performs on call emergency duties for major outages, sewer backups, etc; provides cross training for co-workers and acquires cross training in other trades areas; installs security alarm systems; winterizes and summarizes heating units and air conditioners; provides preventive maintenance and troubleshooting; locates gas or water leaks; checks units for proper operation; performs preventive maintenance program through scheduled inspection and servicing of equipment, housing and facilities; maintains a clean and safe work environment.

KNOWLEDGE, SKILLS AND OTHER CHARACTERISTICS:

Knowledge of common practices, methods, materials and tools of various journey level building, electrical, and plumbing trades.

Knowledge of National Electric Code, Plumbing Code, Building Code and Plumbing Code.

Knowledge of hazards and safety precautions of various trades.

Knowledge of power and technical tool operation related to appliance repair and maintenance.

Knowledge of installation and programming of security alarm systems.

Knowledge of occupational safety and health regulations and practices.

Skill in troubleshooting and repairing a variety of commercial and residential appliances.

Skill in performing semi-skilled tasks of various trades.

Skill in safely working with potentially hazardous materials, chemicals and supplies.

Skill in prioritizing and handling multiple assignments.

Skill in maintaining and repairing power and hand tools and equipment.

Skill in establishing and maintaining effective working relationships.

Skill in welding.

MAINTENANCE TECHNICIAN

Ability to read and work from blueprints, shop drawings and sketches.
Ability to learn relevant building, fire and safety codes.

PHYSICAL REQUIREMENTS AND WORK ENVIRONMENT: Work requires extended hours working, lifting, carrying and transporting heavy tools, appliances, material and equipment weighing in excess of 100 pounds; requires climbing, kneeling, bending stooping and working in confined spaces.

MINIMUM QUALIFICATIONS:

- A high school diploma/GED; and three (3) years of general building maintenance experience in one or more trades area; or an equivalent combination of education and experience.

Special Requirements:

- Possess a valid state driver's license.

PREFERRED QUALIFICATIONS:

- Journeyman level certification
- Occupational Safety and Health Administration training.
- HVAC training or certification.

Supplemental Requirements:

Incumbent must obtain a Navajo Nation Vehicle Operator's Permit within 90 days of date of hire.

Depending upon the needs of the Nation, some incumbents of the class may be required to demonstrate fluency in both the Navajo and English languages as a condition of employment.

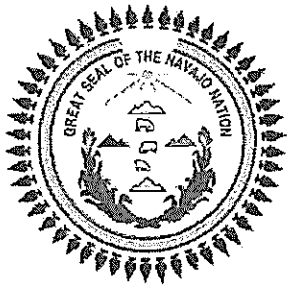

NAVAJO NATION DEPARTMENT OF JUSTICE
OFFICE OF THE ATTORNEY GENERAL

DOREEN N. MCPAUL
Attorney General

KIMBERLY A. DUTCHER
Deputy Attorney General

DEPARTMENT OF JUSTICE
INITIAL ELIGIBILITY DETERMINATION
FOR NAVAJO NATION FISCAL RECOVERY FUNDS

RFS/HK Review #: HK0213

Date & Time Received: 11/15/22 15:40

Date & Time of Response: 11/28/2022 5:00 PM

Entity Requesting FRF: Chinle Chapter Government

Title of Project: Chinle Chapter CYEP and PEP Funding

Administrative Oversight: Division of Community Development

Amount of Funding Requested: \$1,150,953

Eligibility Determination:

- FRF eligible
 FRF ineligible
 Additional information requested

FRF Eligibility Category:

- (1) Public Health and Economic Impact (2) Premium Pay
 (3) Government Services/Lost Revenue (4) Water, Sewer, Broadband Infrastructure

U.S. Department of Treasury Reporting Expenditure Category: 1:14 (Other Public Health Services)

Returned for the following reasons (Ineligibility Reasons / Paragraphs 5. E. (1) - (10) of FRF Procedures):

- | | |
|--|--|
| <input type="checkbox"/> Missing Form | <input type="checkbox"/> Expenditure Plan incomplete |
| <input type="checkbox"/> Supporting documentation missing | <input type="checkbox"/> Funds will not be obligated by 12/31/2024 |
| <input type="checkbox"/> Project will not be completed by 12/31/2026 | <input type="checkbox"/> Incorrect Signatory |
| <input type="checkbox"/> Ineligible purpose | <input type="checkbox"/> Inconsistent with applicable NN or federal laws |
| <input type="checkbox"/> Submitter failed to timely submit CARES reports | |
| <input type="checkbox"/> Additional information submitted is insufficient to make a proper determination | |

Name of DOJ Reviewer: Kristen A. Lowell

Signature of DOJ Reviewer: 

Disclaimers: An NNDOJ Initial Eligibility Determination will be based on the documents provided, which NNDOJ will assume are true, correct, and complete. Should the Project or Program change in any material way after the initial determination, the requestor must seek the advice of NNDOJ. An initial determination is limited to review of the Project or Program as it relates to whether the Project or Program is a legally allowable use – it does not serve as an opinion as to whether or not the Project or Program should be funded, nor does it serve as an opinion as to whether or not the amount requested is reasonable or accurate.

THE NAVAJO NATION
FISCAL RECOVERY FUNDS REQUEST FORM & EXPENDITURE PLAN
FOR GOVERNANCE-CERTIFIED CHAPTERS

Part 1. Identification of parties.

Governance-Certified Chapter requesting FRF: Chinle Chapter Government Date prepared: 10-19-2022

Chapter's mailing address: PO BOX 1809 Chinle, AZ 86503 phone & email: (928) 674-2052 website (if any): chinle@navajochapters.org

This Form prepared by: Dr. Rosanna Jumbo-Fitch phone/email: (928) 225-1658
Chinle Chapter President rosanna.jumbo@naataanii.org
CONTACT PERSON'S name and title *CONTACT PERSON'S info*

Title and type of Project: Chinle Chapter SYEP and PEP Funding

Chapter President: Dr. Rosanna Jumbo-Fitch phone & email: (928) 225-1658/rosanna.jumbo@naataanii.org

Chapter Vice-President: Shawna Claw phone & email: (928) 674-2052/sclaw@navajochapters.org

Chapter Secretary: Roann Burbank phone & email: (928) 674-2052/rburbank@navajochapters.org

Chapter Treasurer: Roann Burbank phone & email: (928) 674-2052/rburbank@navajochapters.org

Chapter Manager or CSC: Walton Yazzie, Manager phone & email: (505)910-9473/wyazzie@navajochapters.org

DCD/Chapter ASO: _____ phone & email: _____

List types of Subcontractors or Subrecipients that will be paid with FRF (if known): Chinle Chapter Government

document attached

Amount of FRF requested: 1,150,953.00 FRF funding period: 2023-2026 10/1/22 - 9/30/25
indicate Project starting and ending/deadline date

Part 2. Expenditure Plan details.

(a) Describe the Program(s) and/or Project(s) to be funded, including how the funds will be used, for what purposes, the location(s) to be served, and what COVID-related needs will be addressed:

Chinle Chapter Government SYEP and PEP Funding would allow additional funding for our Chinle Chapter workforce. The funds will be used for hiring additional members to serve our community members with bathroom additions. The Chinle Chapter is located at Chinle, AZ. The COVID-19 related needs will be met, as bathroom additions are priority project in providing plumbing and running water to our residents.

document attached

(b) Explain how the Program or Project will benefit the Navajo Nation, Navajo communities, or the Navajo People:

The Chinle Chapter SYEP and PEP funding would benefit the Navajo Nation, Chinle community, and our Navajo people by providing funding for employees. The employees would be responsible in managing and constructing bathroom additions for community members.

document attached

(c) A prospective timeline showing the estimated date of completion of the Project and/or each phase of the Project. Disclose any challenges that may prevent you from incurring costs for all funding by December 31, 2024 and/or fully expending funds and completing the Program(s) or Project(s) by December 31, 2026:

Chinle Chapter Government SYEP and PEP Funding Project timeline: Chinle Chapter resolution 10/17/2022, Navajo Nation and DOJ review submissions Winter 2022, Hire Employees and purchase materials and supplies Spring 2023-Winter 2023, Construct bathroom additions Fall 2023-Summer 2026. Challenges would include Navajo Nation review timeline.

document attached

(d) Identify who will be responsible for implementing the Program or Project:

Chinle Chapter Government will be responsible for implementing the project and assistance.

document attached

(e) Explain who will be responsible for operations and maintenance costs for the Project once completed, and how such costs will be funded prospectively:

The Chinle Chapter Government and Local Residents (Bathroom Addition participants) will be responsible for operations and maintenance costs for the project once completed.

document attached

(f) State which of the 66 Fiscal Recovery Fund expenditure categories in the attached U.S. Department of the Treasury Appendix 1 listing the proposed Program or Project falls under, and explain the reason why:

Provision of Government Services 6.1

Chinle Chapter is seeking funding for SYEP and PEP funding in order to continue to provide bathroom additions for the Chinle Chapter residents. Chinle Chapter hires local employees within the Chinle Chapter and surrounding areas to construct bathroom additions (framing, drywall, painting, roofing, and others). Each member are assigned duties in order to promote a clean home environment for each of the households that have applied for the assistance.

document attached

Part 3. Additional documents.

List here all additional supporting documents attached to this FRF Expenditure Plan (or indicate N/A):

Chapter Resolution is attached, SYEP budget, and PEP budget.

Chapter Resolution attached

Part 4. Affirmation by Funding Recipient.

Funding Recipient affirms that its receipt of Fiscal Recovery Funds and the implementation of this FRF Expenditure Plan shall be in accordance with Resolution No. CJY-41-21, the ARPA, ARPA Regulations, and with all applicable federal and Navajo Nation laws, regulations, and policies:

Chapter's Preparer: 
signature of Preparer/CONTACT PERSON

Approved by: 
signature of Chapter President (or Vice-President)

Approved by: 
signature of Chapter Manager or CSC

Approved by: _____
signature of DCD/Chapter ASO

Approved to submit for Review: 
signature of DCD Director

THE NAVAJO NATION
PROGRAM BUDGET SUMMARY

FY 2023

PART I. Business Unit No.: <u>New</u>		Program Title: <u>Chinle PEP and SYEP funding</u>		Division/Branch: <u>DCD / Executive Branch</u>	
Prepared By: <u>Walton Yazzie</u>		Phone No.: <u>928.674.2052</u>		Email Address: <u>wyazzie@nnchapters.org</u>	
PART II. FUNDING SOURCE(S)		PART III. BUDGET SUMMARY		PART IV. POSITIONS AND VEHICLES	
Fiscal Year / Term	Amount	% of Total	Fund Type Code	(A) NNC Original Budget	(B) Proposed Budget
FY23-FY25 <u>10/1/22-9/30/25</u>	1,150,953.00	100%	2001 Personnel Expenses		
			3000 Travel Expenses		
			3500 Meeting Expenses		
			4000 Supplies		
			5000 Lease and Rental		
			5500 Communications and Utilities		
			6000 Repairs and Maintenance		
			6500 Contractual Services		
			7000 Special Transactions		
			8000 Public Assistance	1,150,953	1,150,953
			9000 Capital Outlay		
			9500 Matching Funds		
			9500 Indirect Cost		
			TOTAL	\$0.00	1,150,953.00
				(D)	(E)
			TOTAL # of Positions Budgeted:	43	43
			TOTAL # of Vehicles Budgeted:	0	0
PART V. I HEREBY ACKNOWLEDGE THAT THE INFORMATION CONTAINED IN THIS BUDGET PACKAGE IS COMPLETE AND ACCURATE.					
SUBMITTED BY: <u>Walton Yazzie</u>		APPROVED BY: <u>Lisa Symm</u>		Division Director / Branch Chief's Printed Name	
Program Manager's Printed Name		Signature		Division Director / Branch Chief's Signature and Date	
<u>Walton Yazzie</u>		<u>Lisa Symm</u>		<u>Lisa Symm, NNC DCD</u>	
<u>10.24.22</u>		<u>10.24.22</u>		<u>10.24.22</u>	

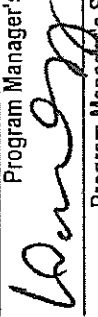
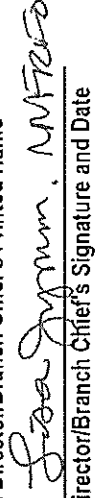
PART I. PROGRAM INFORMATION:		Chinle PEP and SYEP funding											
Business Unit No.:	New	Program Name/Title:											
PART II. PLAN OF OPERATION/RESOLUTION NUMBER/PURPOSE OF PROGRAM:													
PART III. PROGRAM PERFORMANCE CRITERIA:													
		1st QTR		2nd QTR		3rd QTR		4th QTR					
		Goal	Actual	Goal	Actual	Goal	Actual	Goal	Actual	Goal	Actual	Goal	Actual
1. Goal Statement:													
Hire one (1) PEP Project Supervisor													
Program Performance Measure/Objective:													
Need one person to look over all APRA projects		1		1		1		1		1		1	
2. Goal Statement:													
Hire four (4) Carpenter													
Program Performance Measure/Objective:													
Assisting in building approved bathroom addition		4		4		4		4		4		4	
3. Goal Statement:													
Hire one (1) Equipment Operator													
Program Performance Measure/Objective:													
Assist in doing burials, repairing roads, and picking up supplies		1		1		1		1		1		1	
4. Goal Statement:													
Hire one (1) Senior Carpenter and one (1) Accounts Maintenance Specialist													
Program Performance Measure/Objective:													
Assisting in reporting and accountable to APRA Fund		2		2		2		2		2		2	
5. Goal Statement:													
Hire thirty-five (35) SYEP													
Program Performance Measure/Objective:													
Assist in woods, getting PPE ready, and bathroom addition				15		20							
PART IV. I HEREBY ACKNOWLEDGE THAT THE ABOVE INFORMATION HAS BEEN THOROUGHLY REVIEWED.													
Program Manager's Printed Name Walton Yazzie										Division Director/Branch Chief's Printed Name Lisa Szymm			
Program Manager's Signature  10.24.22										Division Director/Branch Chief's Signature and Date  NTF20			

THE NAVAJO NATION
DETAILED BUDGET AND JUSTIFICATION

FY 2023

PART I. PROGRAM INFORMATION:		Business Unit No.:	
Program Name/Title:		Chinle PEP and SYEP funding	
		New	
PART II. DETAILED BUDGET:			
(A)	(B)	(C)	(D)
Object Code (LOD 6)	Object Code Description and Justification (LOD 7)	Total by DETAILED Object Code (LOD 6)	Total by MAJOR Object Code (LOD 4)
8000 8705 8710	Assistance Chapter PEP <i>Chinle Chapter to pay PEP and SYEP workers.</i>	1,150,953	1,150,953
TOTAL			1,150,953

**THE NAVAJO NATION
PROJECT BUDGET SCHEDULE**

PART I. Business Unit No.: <u>New</u> Project Title: <u>Chinle PEP and SYEP Funding</u> Project Description <u>PEP & SYEP workers to complete bathroom addition</u>	PART II. Project Information Project Type: <u>Chinle PEP & SYEP Funding</u> Planned Start Date: <u>10/1/2022</u> Planned End Date: <u>9/30/2025</u> Project Manager: <u>Walton Yazzie</u>
Check one box: <input checked="" type="checkbox"/> Original Budget <input type="checkbox"/> Budget Revision <input type="checkbox"/> Budget Reallocation <input type="checkbox"/> Budget Modification	

PART III. List Project Task separately, such as Plan, Design, Construct, Equip or Furnish.	FY <u>2023</u>												FY <u>2024</u>												Expected Completion Date if project exceeds 8 FY Qtrs.						
	1st Qtr.			2nd Qtr.			3rd Qtr.			4th Qtr.			1st Qtr.			2nd Qtr.			3rd Qtr.			4th Qtr.				Date					
	O	N	D	J	F	M	A	M	J	S	A	Jul	O	N	D	J	F	M	A	M	J	S	A	Jul			O	N	D	J	F
Hire (1) PEP Project Supervisor	X	X	X	X	X	X	X	X	X	X	X	X	X	X	X	X	X	X	X	X	X	X	X	X	X	X	X	X	X	X	
Hire (1) Senior Carpenter	X	X	X	X	X	X	X	X	X	X	X	X	X	X	X	X	X	X	X	X	X	X	X	X	X	X	X	X	X	X	
Hire (1) Equipment Operator	X	X	X	X	X	X	X	X	X	X	X	X	X	X	X	X	X	X	X	X	X	X	X	X	X	X	X	X	X	X	
Hire (1) Accounts Maintenance Specialist	X	X	X	X	X	X	X	X	X	X	X	X	X	X	X	X	X	X	X	X	X	X	X	X	X	X	X	X	X	X	
Hire (4) Carpenter	X	X	X	X	X	X	X	X	X	X	X	X	X	X	X	X	X	X	X	X	X	X	X	X	X	X	X	X	X	X	
Hire 35 SYEP																															
PART V.	\$			\$			\$			\$			\$			\$			\$			\$			PROJECT TOTAL			\$	\$767,301.88		

FOR OMB USE ONLY: Resolution No: _____ FMIS Set Up Date: _____ Company No: _____ OMB Analyst: _____

THE NAVAJO NATION
PROJECT BUDGET SCHEDULE

PART I. Business Unit No.: New **PART II.** Project Information
Project Title: Chinle PEP and SYEP Funding Project Type: Chinle PEP & SYEP Funding
Project Description: PEP & SYEP workers to complete bathroom addition Planned Start Date: 10/1/2022
Planned End Date: 9/30/2025
Project Manager: Walton Yazzie

Check one box:
 Original Budget Budget Revision Budget Reallocation Budget Modification

PART III. List Project Task separately, such as Plan, Design, Construct, Equip or Furnish.

	FY 2025												Date						
	1st Qtr.			2nd Qtr.			3rd Qtr.			4th Qtr.				4th Qtr.					
	O	N	D	J	F	M	A	M	A	M	J	A		S	O	N	D	J	F
Hire (1) PEP Project Supervisor	X			X	X	X	X	X	X	X	X								
Hire (1) Senior Carpenter	X			X	X	X	X	X	X	X	X								
Hire (1) Equipment Operator	X			X	X	X	X	X	X	X	X								
Hire (1) Accounts Maintenance Specialist	X			X	X	X	X	X	X	X	X								
Hire (4) Carpenter	X			X	X	X	X	X	X	X	X								
Hire 35 SYEP	X			X	X	X	X	X	X	X	X								

PART IV. Use Fiscal Year (FY) Quarters to complete the information below. O = Oct.; N = Nov.; D = Dec., etc.

	FY _____																							
	1st Qtr.			2nd Qtr.			3rd Qtr.			4th Qtr.			1st Qtr.			2nd Qtr.			3rd Qtr.			4th Qtr.		
Expected Quarterly Expenditures	\$ 80,767.56			\$ 80,767.56			\$ 106,730.76			\$ 115,385.16			\$			\$			\$			\$383,651.12		

PART V. Grand Total: 1,150,953.00
OMB Analyst: _____
Company No: _____
FMS Set Up Date: _____
Resolution No: _____

Chinle Chapter Government

THE NAVAJO NATION

Dr. Rosanna Jumbo-Fitch
PRESIDENT

Shawna Claw
VICE PRESIDENT

RoAnn Burbank
SECRETARY/TREASURER

Eugene Tso
COUNCIL DELEGATE

Oscar Bia
GRAZING COMMITTEE MEMBER

RESOLUTION OF THE CHINLE CHAPTER NAVAJO NATION CHIN-OCT-22-074

APPROVING THE SELECTION OF THE SYEP/PEP FUNDING PROJECT FOR THE INCLUSION ON THE CHINLE CHAPTER DELEGATE REGION IN THE AMOUNT OF \$1,150,953.00.

WHEREAS:

1. Pursuant to Navajo Nation Code, Section 4001 (d) and 4028 (2), (b) the Chinle Chapter is established and certified as a local government entity of the Navajo Nation vested with the authority to review all matters affecting the chapter and submit appropriate recommendations to the Navajo Nation government of other local agencies by resolutions; and
2. To support the efforts of the Navajo Nation to mitigate the effects of the COVID-19 Pandemic, the American Rescue Plan Act (ARPA) Fiscal Recovery Funds were allocated to develop the basic infrastructure to improve lives of people who have lived without water, electricity and "basic services to support their daily activities, health, and welfare"; and
3. The Navajo Nation Council approved CJN-29-22, in response to the COVID-19 Pandemic in the best interest of the people: "An Action Relating to the Naabik'iyati' Committee and Navajo Nation Council; Allocating \$1,070,298,867 of Navajo Nation Fiscal Recovery Funds; Approving the Navajo Nation Fiscal Recovery Fund Expenditure Plans for Chapter Assistance; Public Safety Emergency Communications, E911, and Rural Addressing Projects; Cyber Security Public Health Projects; Economic Development Projects; Hardship Assistance; Water and Wastewater Projects Broadband Projects; Home Electricity Connection and Electricity Capacity Projects; Housing Projects and Manufactured Housing Facilities; Bathroom Addition Projects; Construction Contingency Funding; and Reduce Administrative Funding"; and
4. The Chinle Chapter Government has attended several meetings with Navajo Nation Division of Community Development, Navajo Tribal Utility Authority, and the Fiscal Recovery Fund Office; and
5. The eligible attached Exhibit: Chinle Chapter SYEP/PEP Funding was selected as a Project to be included on the Navajo Nation Council Delegate Eugene Tso Chapter Region in the amount of \$1,150,953.00 for the Chinle Chapter; and
6. The total amount for Chinle Chapter Delegate Region is \$ 8,802,340.00.

NOW, THEREFORE BE IT RESOLVED THAT:

1. The Chinle Chapter Government hereby approves the selection of Chinle Chapter SYEP/PEP Funding was a selected Project to be included on the Navajo Nation Council Delegate Eugene Tso Chapter Region in the amount of \$1,150,953.00.

CERTIFICATION

We hereby certify that the foregoing chapter resolution was duly considered by the Chinle Chapter at a duly called meeting at which time a quorum was present. A motion was made by Oscar Bia Sr. and seconded by Shawna Spencer and the same was passed by a vote of 10 in favor, 0 opposed, and 1 abstained, this 17th day of October, 2022.



Dr. Rosanna Jumbo-Fitch, President



Shawna Claw, Vice President



RoAnn Burbank, Secretary/Treasurer

FY2023
Summer youth employment program

SYEP	Wage	Hire 35 SYEP @ 10.00 for	56000	
	SS	160 hours	3472	
	MED		812	
	WC		296.8	
				60580.8

PEP workers

PEP	Wage	Hire 1 Senior Carpenter	40622.40	
	SS	at 19.53 for 2080 hours	2518.59	
	MED		589.02	
	WC		215.30	
	SUTA		743.39	
				44688.70

PEP	Wage	Hire 1 Carpenters @ 16.41	34132.80	
	SS	for 2080 hours	2116.23	
	MED		494.93	
	WC		180.90	
	SUTA		624.63	
				37549.49

PEP	Wage	Hire 1 Carpenters @ 16.41	34132.80	
	SS	for 2080 hours	2116.23	
	MED		494.93	
	WC		180.90	
	SUTA		624.63	
				37549.49

PEP	Wage	Hire 1 Carpenters @ 16.41	34132.80	
	SS	for 2080 hours	2116.23	
	MED		494.93	
	WC		180.90	
	SUTA		624.63	
				37549.49

PEP	Wage	Hire 1 Carpenters @ 16.41	34132.80	
	SS	for 2080 hours	2116.23	
	MED		494.93	

	WC		180.90	
	SUTA		624.63	
				37549.49
PEP	Wage	Hire 1 Equipment Operator	31387.20	
	SS	at 15.09 for 2080 hours	1946.01	
	MED		455.11	
	WC		166.35	
	SUTA		574.39	
				34529.06
PEP	Wage	Hire 1 Project Coordinator	40622.40	
	benefits	at 19.53 for 2080 hours	21148.02	
	WC		215.30	
				61985.72
PEP	Wage	Hire 1 Accounts Maintenance	28787.20	
	SS	at 13.84 for 2080 hours	1784.81	
	MED		417.41	
	WC		152.57	
	SUTA		526.81	
				31668.80
			<u>\$ 383,651.05</u>	

FY2024
Summer youth employment program

SYEP	Wage	Hire 35 SYEP @ 10.00 for	56000	
	SS	160 hours	3472	
	MED		812	
	WC		296.8	
				60580.8
		PEP workers		
PEP	Wage	Hire 1 Senior Carpenter	40622.40	
	SS	at 19.53 for 2080 hours	2518.59	
	MED		589.02	
	WC		215.30	
	SUTA		743.39	
				44688.70
PEP	Wage	Hire 1 Carpenters @ 16.41	34132.80	
	SS	for 2080 hours	2116.23	
	MED		494.93	
	WC		180.90	
	SUTA		624.63	
				37549.49
PEP	Wage	Hire 1 Carpenters @ 16.41	34132.80	
	SS	for 2080 hours	2116.23	
	MED		494.93	
	WC		180.90	
	SUTA		624.63	
				37549.49
PEP	Wage	Hire 1 Carpenters @ 16.41	34132.80	
	SS	for 2080 hours	2116.23	
	MED		494.93	
	WC		180.90	
	SUTA		624.63	
				37549.49
PEP	Wage	Hire 1 Carpenters @ 16.41	34132.80	
	SS	for 2080 hours	2116.23	
	MED		494.93	

	WC		180.90	
	SUTA		624.63	37549.49
PEP	Wage	Hire 1 Equipment Operator	31387.20	
	SS	at 15.09 for 2080 hours	1946.01	
	MED		455.11	
	WC		166.35	
	SUTA		574.39	34529.06
PEP	Wage	Hire 1 Project Coordinator	40622.40	
	benefits	at 19.53 for 2080 hours	21148.02	
	WC		215.30	61985.72
PEP	Wage	Hire 1 Accounts Maintenance	28787.20	
	SS	at 13.84 for 2080 hours	1784.81	
	MED		417.41	
	WC		152.57	
	SUTA		526.81	31668.80
			<u>\$ 383,651.05</u>	

FY2025
Summer youth employment program

SYEP	Wage	Hire 35 SYEP @ 10.00 for	56000	
	SS	160 hours	3472	
	MED		812	
	WC		296.8	
				60580.8

PEP workers

PEP	Wage	Hire 1 Senior Carpenter	40622.40	
	SS	at 19.53 for 2080 hours	2518.59	
	MED		589.02	
	WC		215.30	
	SUTA		743.39	
				44688.70

PEP	Wage	Hire 1 Carpenters @ 16.41	34132.80	
	SS	for 2080 hours	2116.23	
	MED		494.93	
	WC		180.90	
	SUTA		624.63	
				37549.49

PEP	Wage	Hire 1 Carpenters @ 16.41	34132.80	
	SS	for 2080 hours	2116.23	
	MED		494.93	
	WC		180.90	
	SUTA		624.63	
				37549.49

PEP	Wage	Hire 1 Carpenters @ 16.41	34132.80	
	SS	for 2080 hours	2116.23	
	MED		494.93	
	WC		180.90	
	SUTA		624.63	
				37549.49

PEP	Wage	Hire 1 Carpenters @ 16.41	34132.80	
	SS	for 2080 hours	2116.23	
	MED		494.93	